

3.7m/12ft 1in Box Van 350L

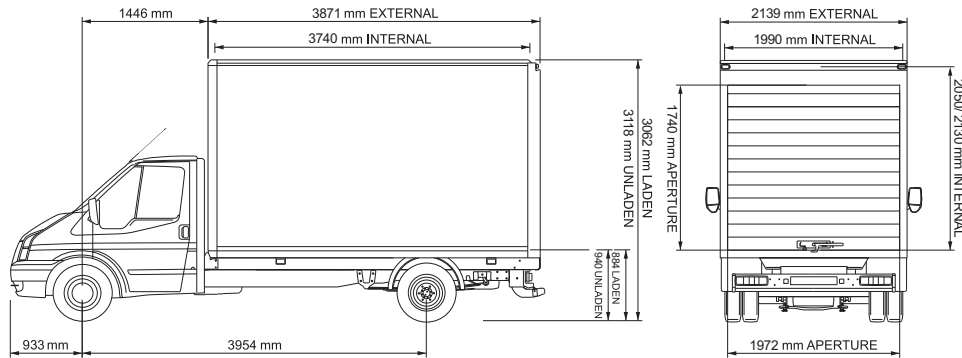

4.1m/13ft 5in Box Van 350EF

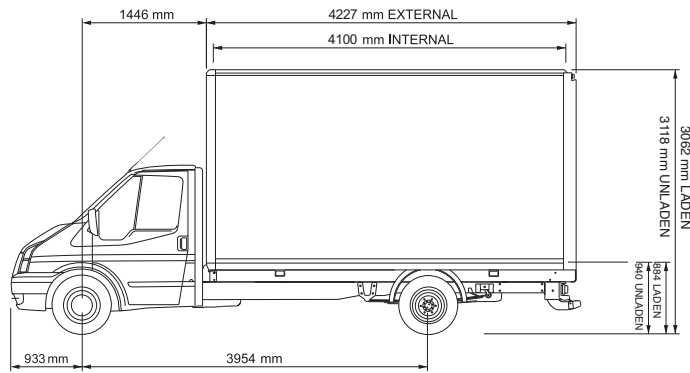

Illustrations above show optional rear door latch

Weights and loads

	Rear axle ratio	350L	350EF
Plated weights (kg)			
FAM		1750	1750
FAM – Optional		1850	1850
RAM		2450	2450
GVM		3500	3500
GTM 115PS (2.4L)*	4.27	6000	6000
GTM 140PS (2.4L)*	4.27	6300	6300
Payload 6 speed trans (115/140PS)*		1075	1000
Cubic capacity m ³		15.5	17.1

*RPO trailer tow attachment not available, furthermore aftermarket tow attachments are precluded by the rear step or optional Tail-Lift. *Payloads quoted are gross (full tank of fuel, oil and fluids, no driver) and for minimum specification, optional chassis equipment including 1850Kg front axle and optional body equipment will reduce payload allowance. Subject to manufacturing tolerance. **FAM** = Front axle plated mass. **RAM** = Rear axle plated mass. **GVM** = Gross vehicle mass. **GTM** = Gross train mass.

Specifications

	Chassis Cab
Chassis	
Engine availability – Please refer to chart (page 24)	
Transmission – 115/140 PS – 6-speed MT82	●
Rear Axle – 115 PS – dual rear wheel 4.27 ratio	●
Rear Axle – 140 PS – dual rear wheel 4.27 ratio	●
Tyres – 185/75 R16C 104/102 (1750Kg front axle)	●
Tyres – 195/75 R16C 107/105 (1850Kg front axle)	○
Suspension – Front, coil spring MacPherson strut. Rear, taper leaf + helper. Roll bars front and rear	●
Seating – Driver's seat and dual passenger seat, lap and diagonal seat belts to all seats	●
Electrical – Battery: 12V 2 x 590CCA (60Ah @ 20 hr rate) batteries, primary battery isolator relay	●
Cold start (-29°C) includes twin 680 CCA (70Ah @ 20h rate) batteries – recommended if optional Tail-Lift specified	○
Electrical – Alternator: 150 Amp	●
Colour – Frozen White only	●
Body	
Type – Ply/GRP panel Box, shutter door, alu framed with steel rear frame for retro-fit Tail-lift capability (Ratcliff only)	●
Colour – Frozen white only – Ply/GRP composite panels and uPVC rear shutter exterior and interior. Natural anodised aluminium exterior frame work and mill finish aluminium internal load restraint rails	●
Understructure – Full-length anodised 6082 T6 aluminium longitudinals, galvanized closed 'C' section crossbearers	●
Bodysides – Self-coloured 6mm Ply/GRP composite panels, aluminium reinforcements moulded into interior surface for load retention rails	●
Structure – Extruded aluminium frame anodised, with cast aluminium corner sockets	●
Rear Frame – Powder-coated steel frame incorporating end outline marker lamps, rain channel, anti-slip tape to rear aperture step. ASTM.B117-03 BS7479:1991 DIN.50.021-SS, 960hr salt spray compliant.	●

Specifications

	Chassis Cab
Roof – Translucent GRP roof panels with alternate alloy panels, crowned aluminium roof sticks	●
Floor – Embossed 15 mm thick phenolic resin full birch plywood	●
Door – uPVC slat rear shutter, extruded aluminium lower plank powder-coated white with lower lip seal. External rubber lip seals to door frame aperture sides, two exterior grab handles with one internal webbing pull cord.	●
Door Lock – Slam shut latch with built in lock, door latched to door frame sides using paddle latch's. Internal emergency door release system with high strength steel load protection panel to lower shutter panel	●
Handrail – 3/4 height, mounted at the rear near-side, with integral switchgear	●
Lighting – 35W work lamp mounted on rear of interior handrail, can be rotated to illuminate interior and exterior	●
Rear Step – Full-width aluminium, powder-coated grey	●
Load Lashing – Interior Load restraint system, 4 horizontal rails per bodyside with twin integral orange coloured rubber strips per rail. 3x400kg rated telescopic 6082 T6 load retention poles.	●
Hardware: Zinc plated to ASTM.B117-03 BS7479:1991 DIN.50.021-SS, 504hr salt spray compliant	●
Body Warranty – 3-year, 100,000 miles	●
Optional Bodywork equipment from bodywork supplier (consult Dealer for further details)	
Luton head	○
Luton head load retention net	○
Tail-lift - Ratcliff RQ08 lightweight aluminium column lift, 500Kg capacity, trolley stops, dual control, 950mm platform depth. RPO Cold Start (-29°C) twin 680 CCA (70Ah @ 20h rate) batteries recommended at extra cost with this option.	○
Additional telescopic load retention poles	○
Additional load lashing rails	○
Ply lining kit	○
Reverse alarm	○

● = Standard, ○ = Option, at extra cost. RPO tow bar is not available, 350HD and 460 derivatives not available. **NOTE: Drawings are representative and may be subject to change. Optional rear door latch shown, fittings and equipment subject to change.**